

# Memory management

Daniel Hagimont (INPT)

Thanks to Noël De Palma, Fabienne Boyer and  
Arnaud Legrand (UJF)

# Introduction

- Memory is a resource required by all processes
  - Every program needs to be loaded in memory to be running
- Problems
  - Address translation
    - Symbol → Logical address → physical address
  - Memory allocation and exhaustion
  - Memory sharing
  - Memory protection

# Life cycle of a single program

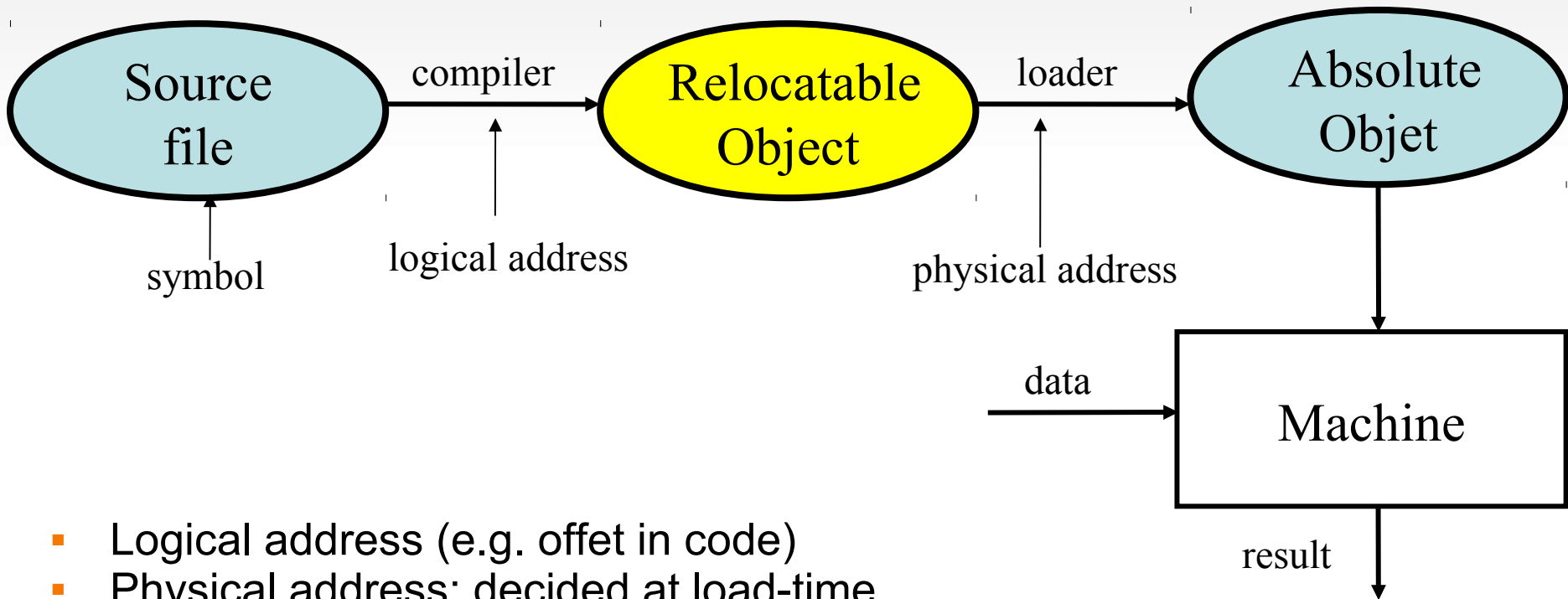

- Logical address (e.g. offset in code)
- Physical address: decided at load-time

# Lifecycle of a program assembled from multiple parts

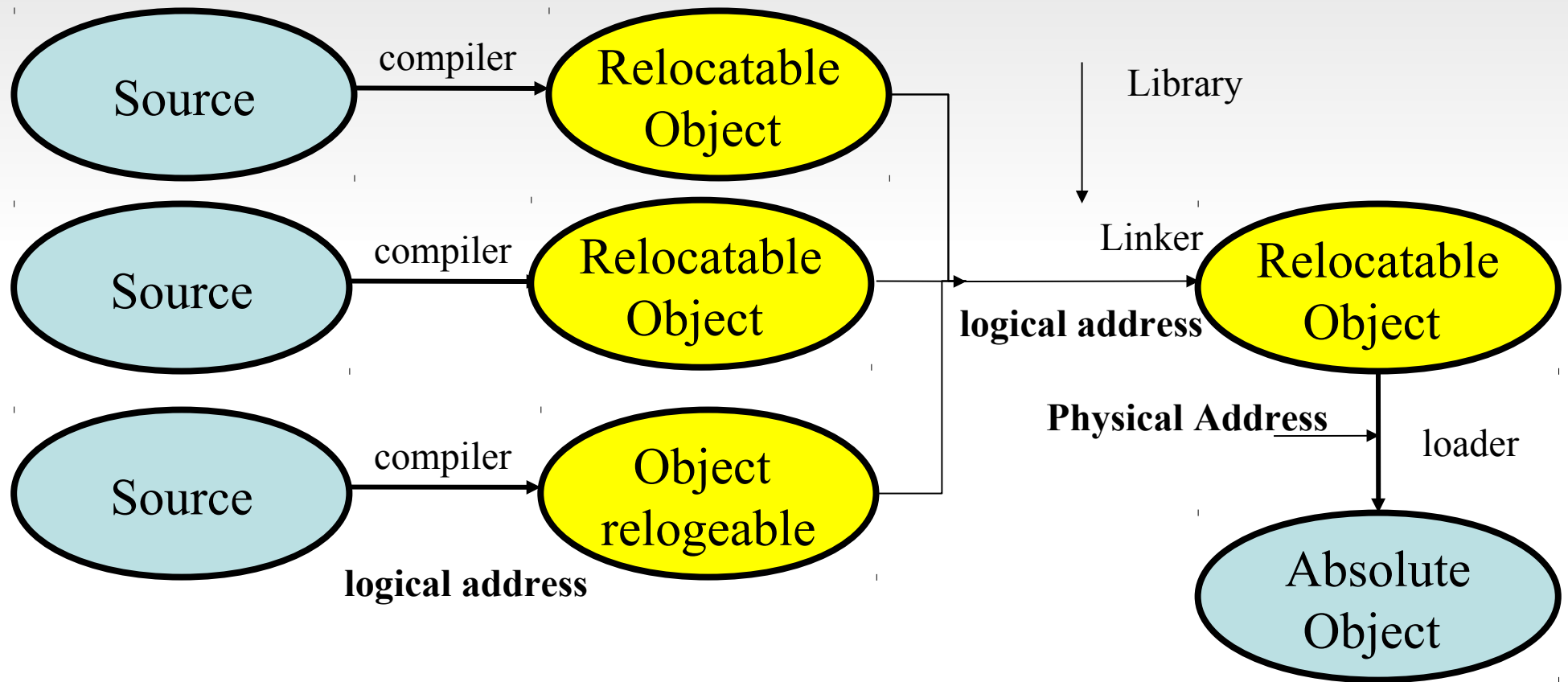

# Load-time translation

- Translation between logical and physical addresses
  - Determine where process will reside in memory
  - Translate all references within program
  - Established once for all
- Monoprogramming
  - One program in memory
  - Easy (could even be done before load-time)
- Multiprogramming
  - N programs in memory
  - Compiler and linker do not know the implantation of processes in memory
  - Need to track op-codes that must be updated at load-time

# Simple program binary structure

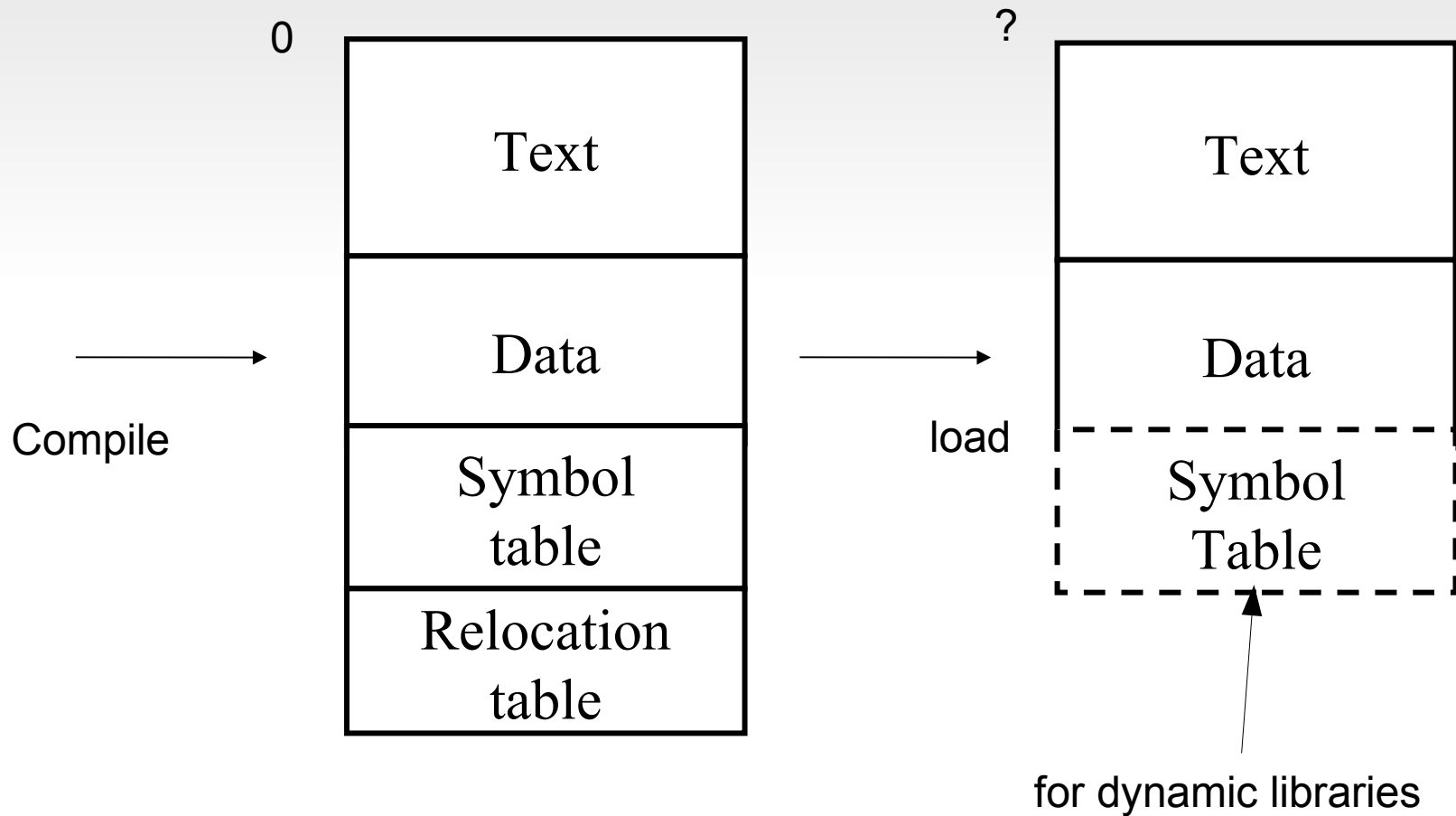

# Complex program binary structure

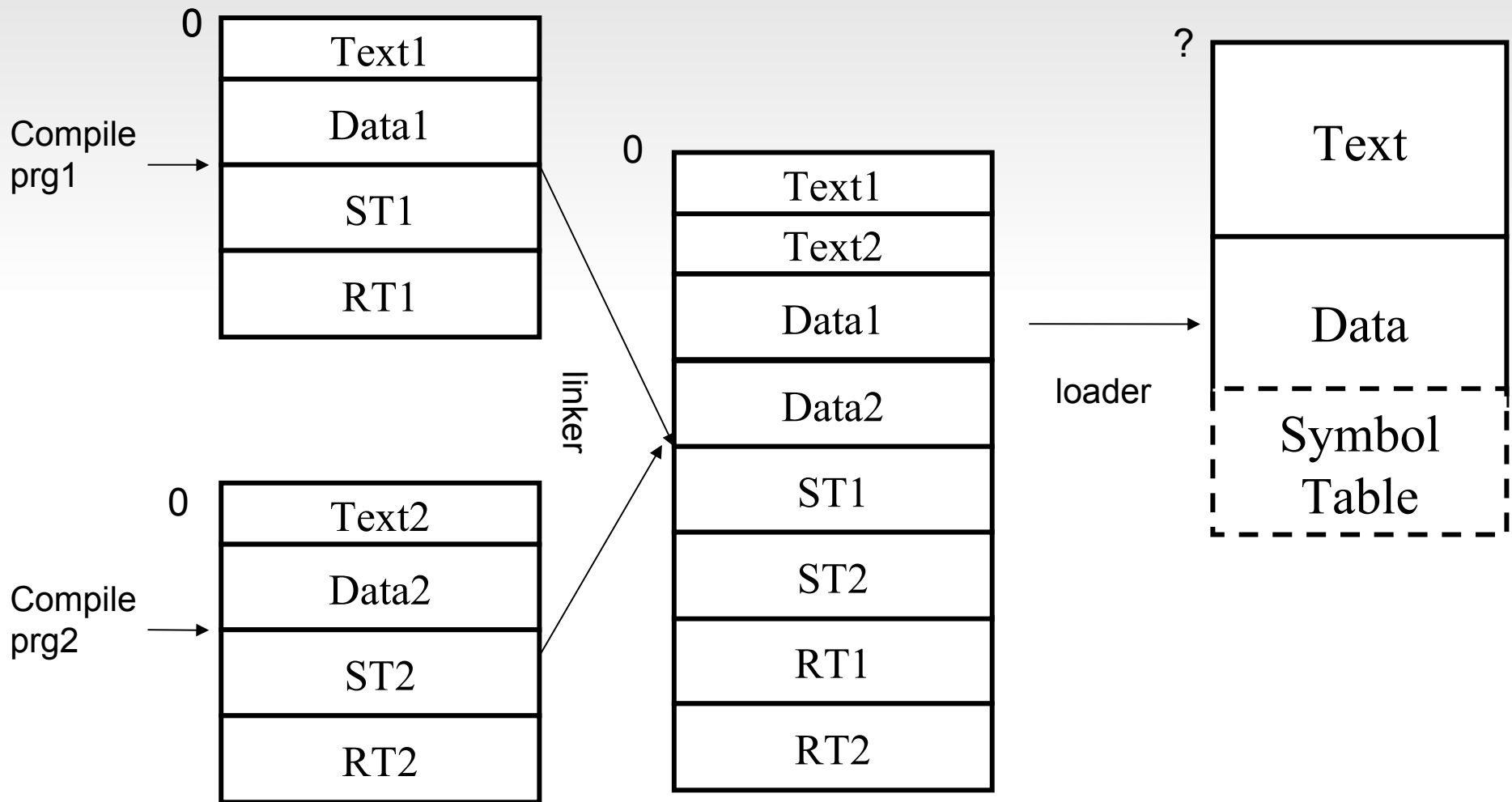

# Load-time translation summary

- Remaining problems
  - How to enforce protection ?
  - How to move program once in memory ?
  - What if no contiguous free region fits program size ?
  - Can we separate linking from memory management problems ?



# Virtual memory

- Separate linking problem from memory management
- Give each program its own virtual address space
  - Linker works on virtual addresses
  - Virtual address translation done at runtime
    - Relocate each load/store to its physical address
    - Require specific hardware (MMU)

# Virtual memory

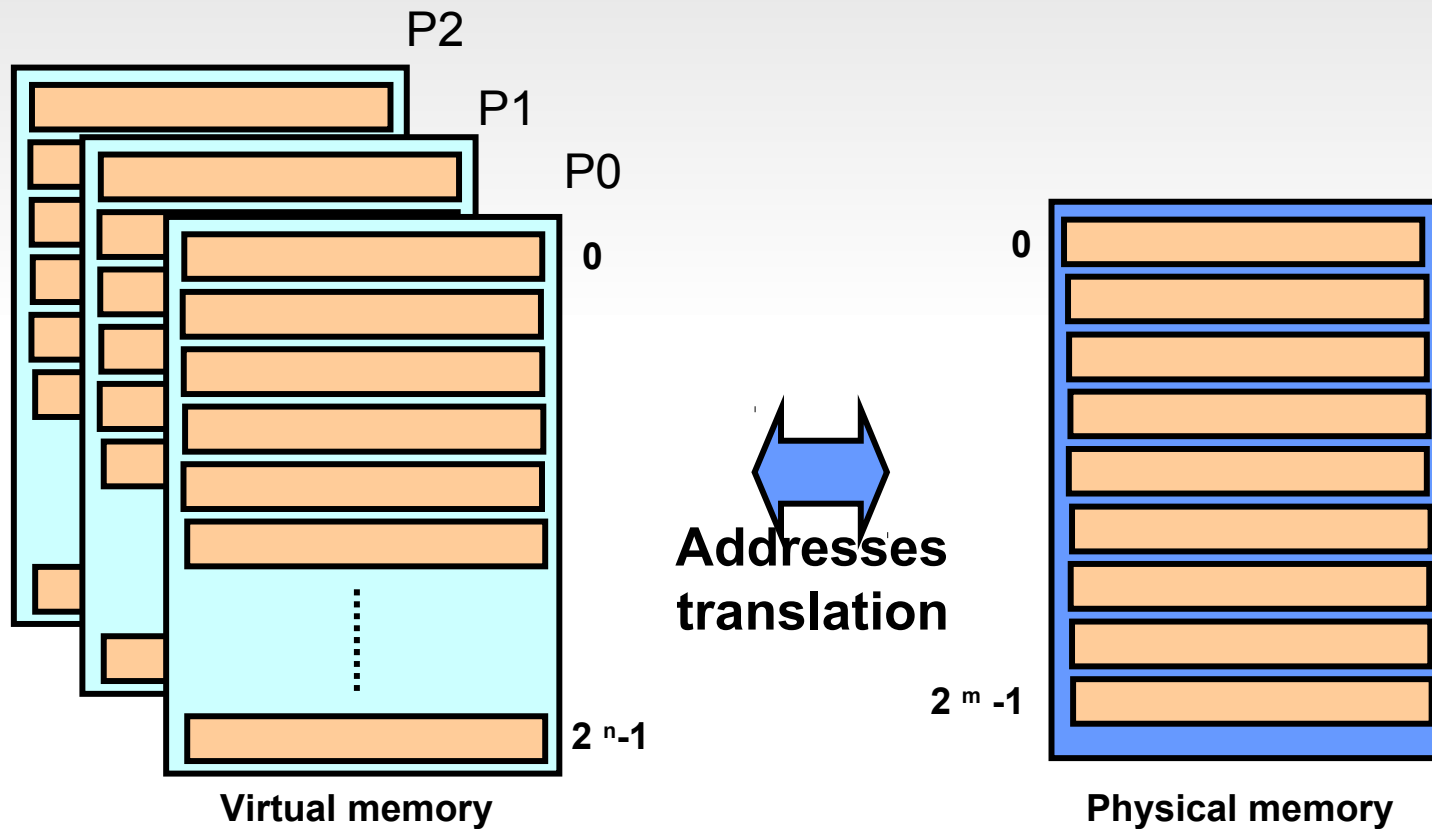

**Ideally we want to enable  $n > m$  and non contiguous allocation**

# Virtual memory expected benefits

- Programs can be relocated while running
  - Ease swap in/swap out
- Enforce protection
  - Prevent one app from messing with another's memory
- Programs can see more memory than exists
  - Most of a process's memory will be idle
  - Write idle part to disk until needed (swap)

# 1st idea : Base + bound registers

- Contiguous allocation of variable size
- Two special privileged registers: base and bound
- On each load/store:
  - Check  $0 \leq \text{virtual address} < \text{bound}$ , else trap to kernel
  - Physical address = virtual address (plus) base

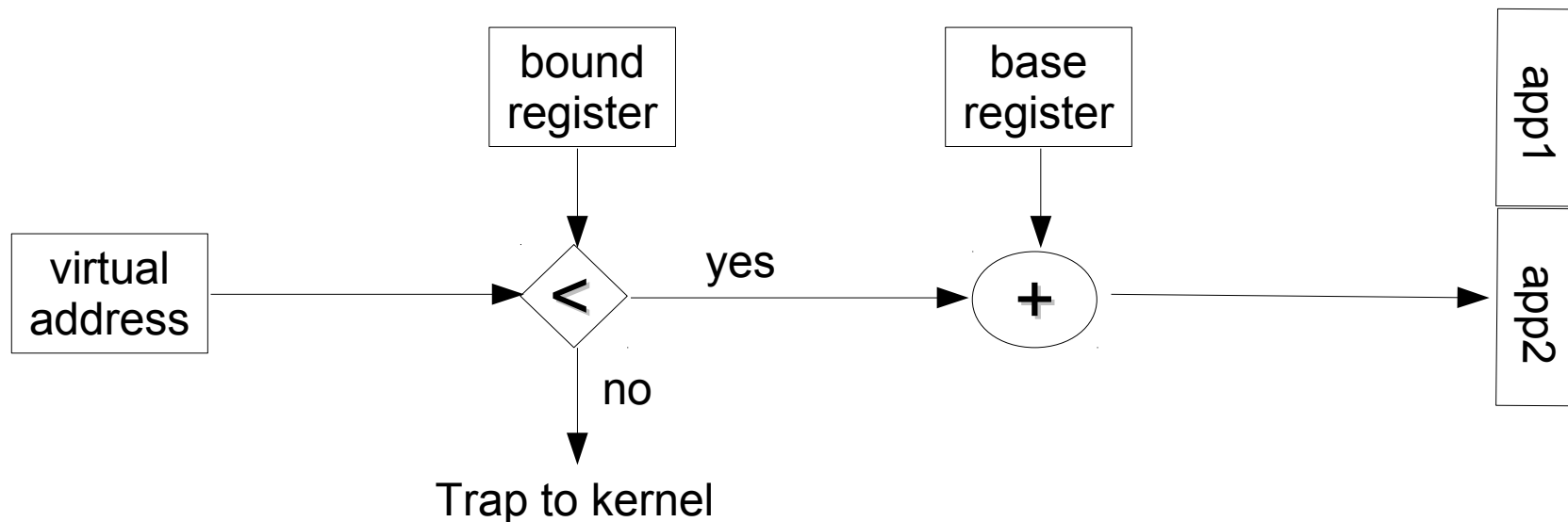

# Base + bounds register

- Moving a process in memory
  - Change base register
- Context switch
  - OS must re-load base and bound register
- Advantages
  - Cheap in terms of hardware: only two registers
  - Cheap in terms of cycles: do add and compare in parallel
- Disadvantages
  - Still contiguous allocation
  - Growing a process is expensive or impossible
  - Hard to share code or data

# Segmentation

- Non contiguous allocation
  - Split a program in different non contiguous segments of variable size
- Let processes have many base/bound registers
  - Address space built from many segments
  - Can share/protect memory at segment granularity
- Must specify segment as part of virtual address

# Segmentation

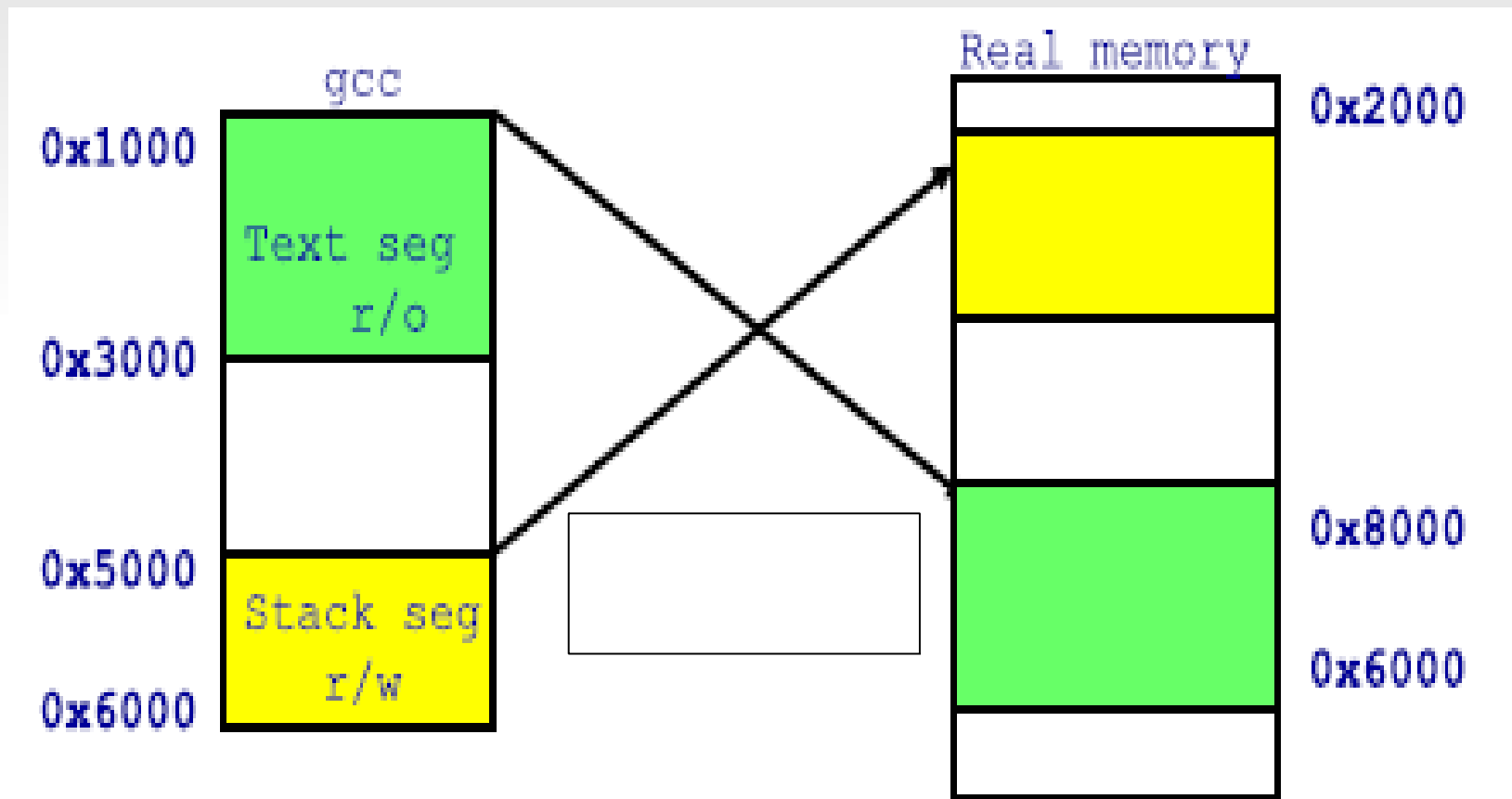

# Segmentation mechanism

- Each process has a segment table
  - Each virtual address indicates a segment and offset:
    - Top bits of addr select segment, low bits select offset

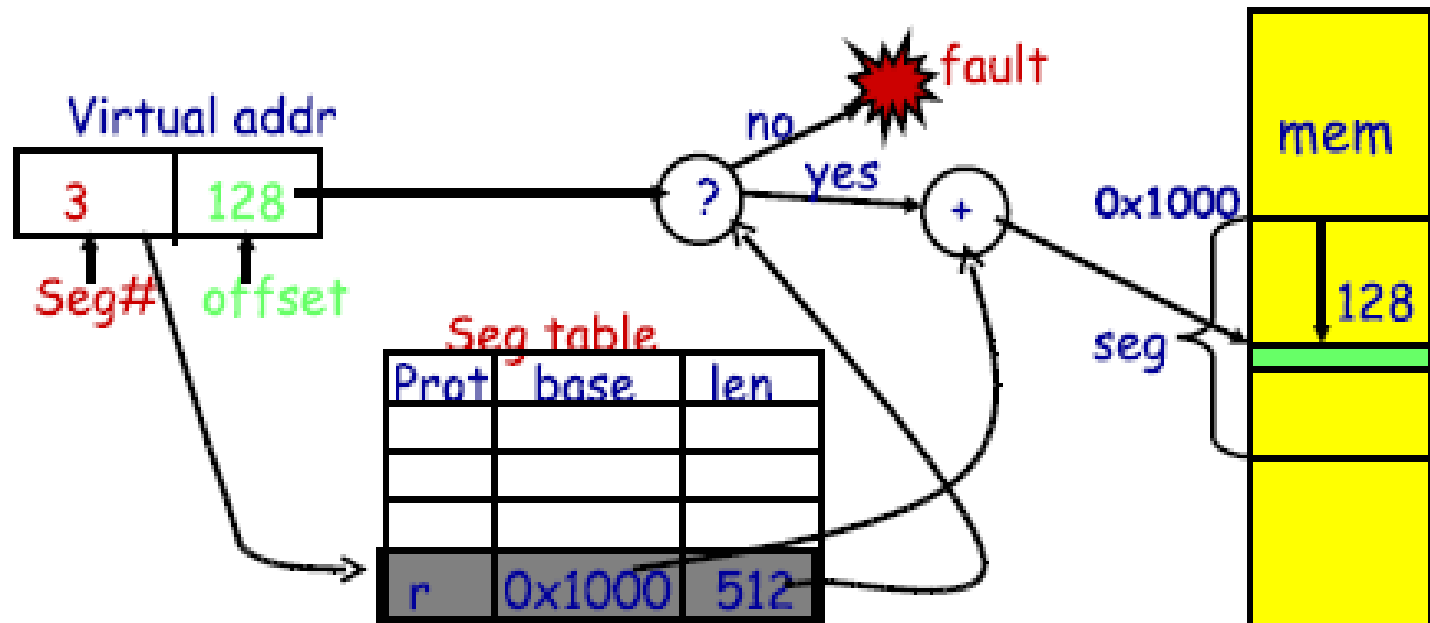



# Segmentation example

- 4-bit segment number (1st digit), 12 bit offset (last 3)
  - Where is 0x0240? 0x1108? 0x265c? 0x3002? 0x1600?

Seg	base	bounds	rw
0	0x4000	0x6fff	10
1	0x0000	0x4fff	11
2	0x3000	0xffff	11
3			00

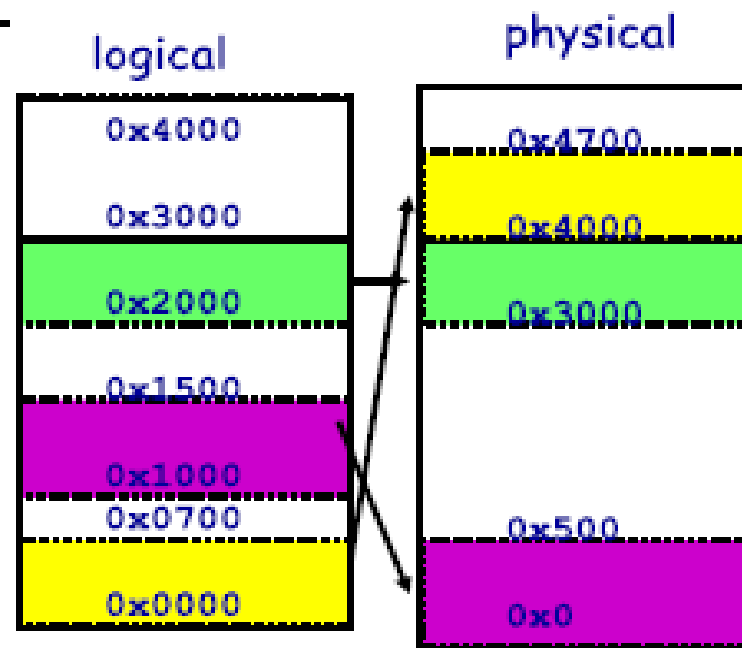

# Segmentation tradeoffs

- Advantages
  - Multiple segments per process
  - Allows sharing
- Disadvantages
  - N byte segment needs N contiguous bytes of physical memory
  - Fragmentation

# Remember fragmentation problem

- Fragmentation => inability to use free memory
- Overtime:
  - Variable-size pieces = many small holes (external fragmentation)

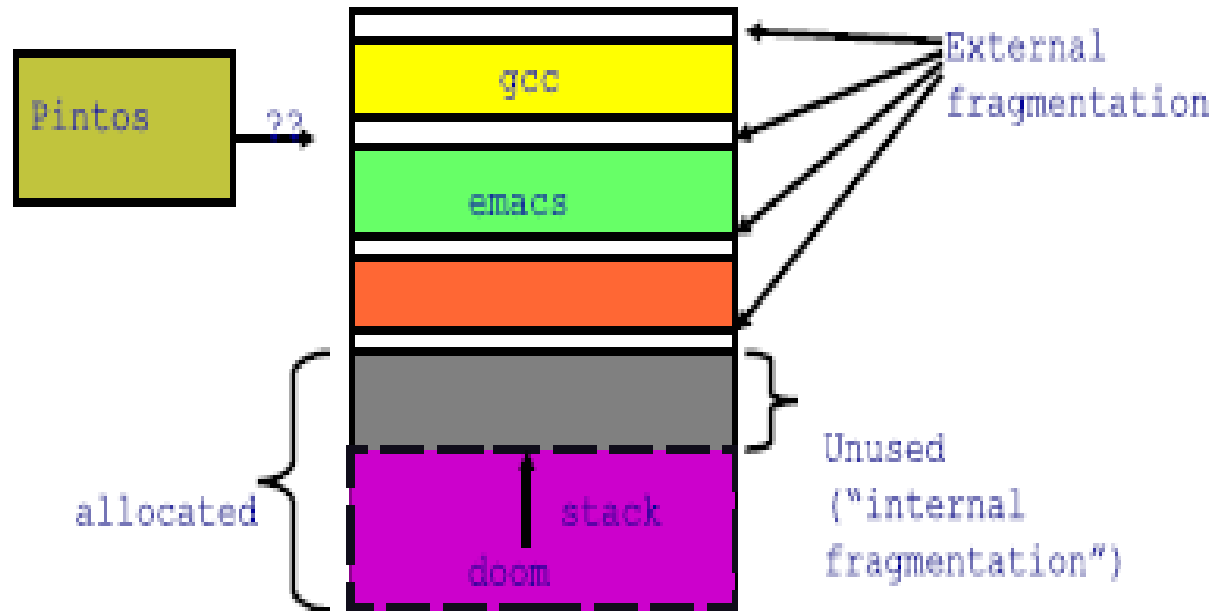

# Paging

- Virtual memory is divided into small pages
  - Pages are fixed size
  - A page is contiguous
- Map virtual pages to physical block
  - Non contiguous allocation of blocks
  - Each process has a separate mapping but can share the same physical block
  - MMU
- OS gains control on certain operations
  - Non allocated pages trap to OS on access
  - Read only pages trap to OS on write
  - OS can change the mapping

# Paging

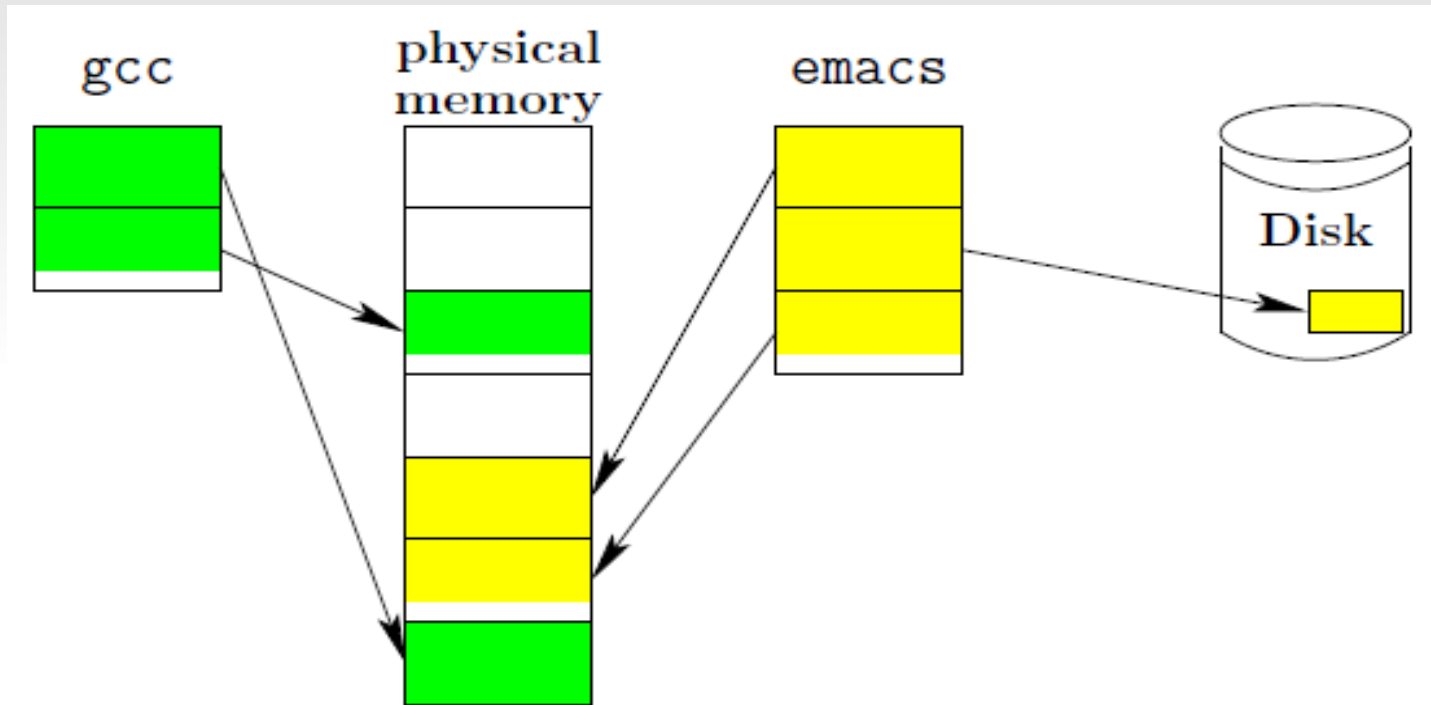

- Page table
  - Global or per process

# Virtual address translation

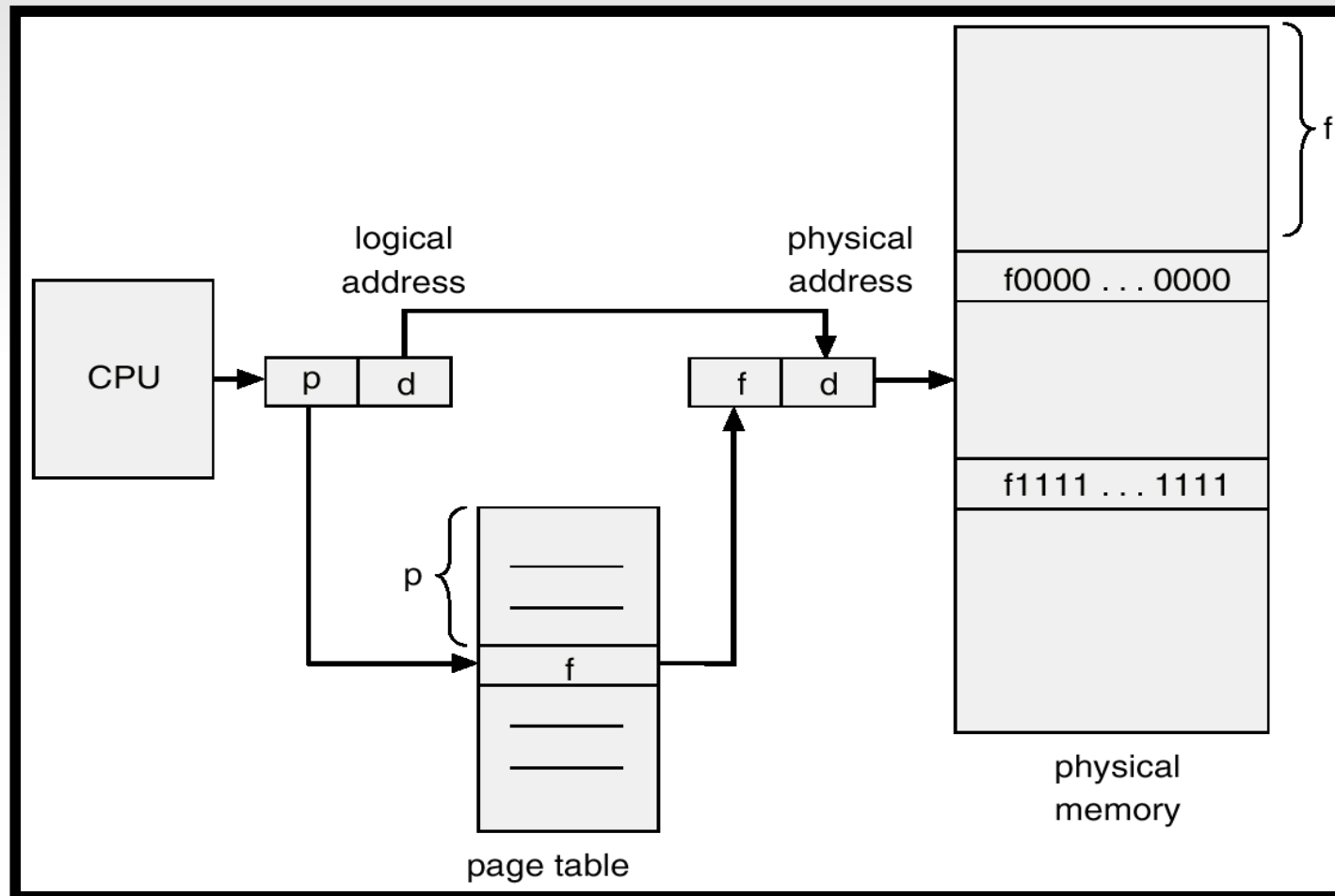

# Problem : translation speed

- Require extra memory references on each load/store
  - Cache recently used translations
  - Locality principle
    - High probability that the next required address is close
- Translation Lookaside Buffer (TLB)
  - Fast (small) associative memory which can perform a parallel search
  - Typical TLB
    - Hit time : 1 clock cycle
    - Miss rate 1%
  - TLB management : hardware or software

# TLB

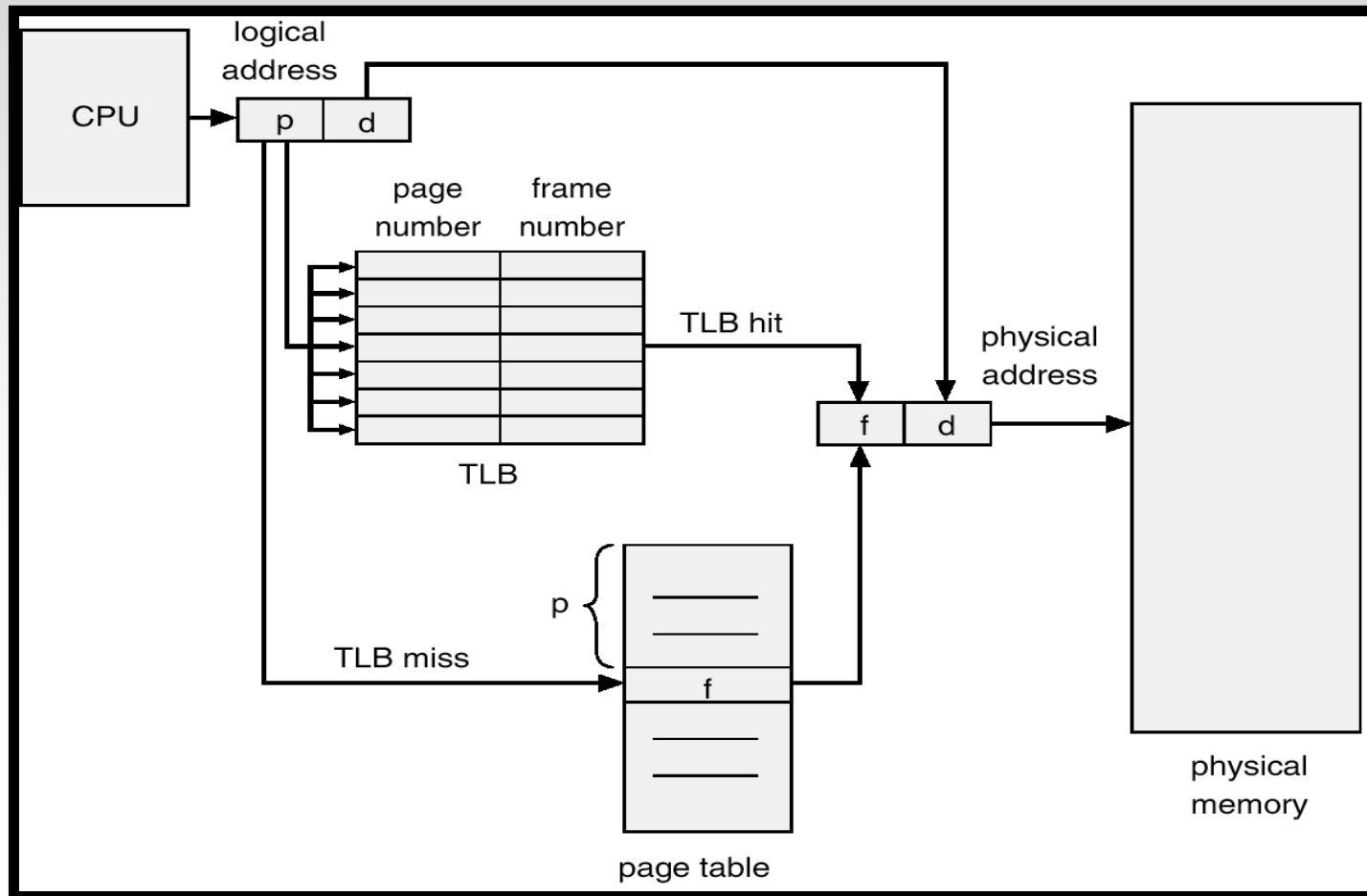

- What to do when switch address space ?
  - Flush the TLB
  - Tag each entry with the process's id
- Update TLB on page fault (add/remove TLB entries)



# Problem : page table size

- Flat page tables are huge
- Example
  - 4GB of virtual memory (32 bits address)
  - 4KB pages
  - 20bits page number, 12 bits offset
  - 1MB page table size :<

# Multi-level page tables

- Reduce the size of page tables in memory
- Structured page tables in 2 or more levels
  - All the page tables are not present in memory all the time
  - Some page tables are stored on disk and fetched if necessary
- Based on a on-demand paging mechanism

# Example: two level pages

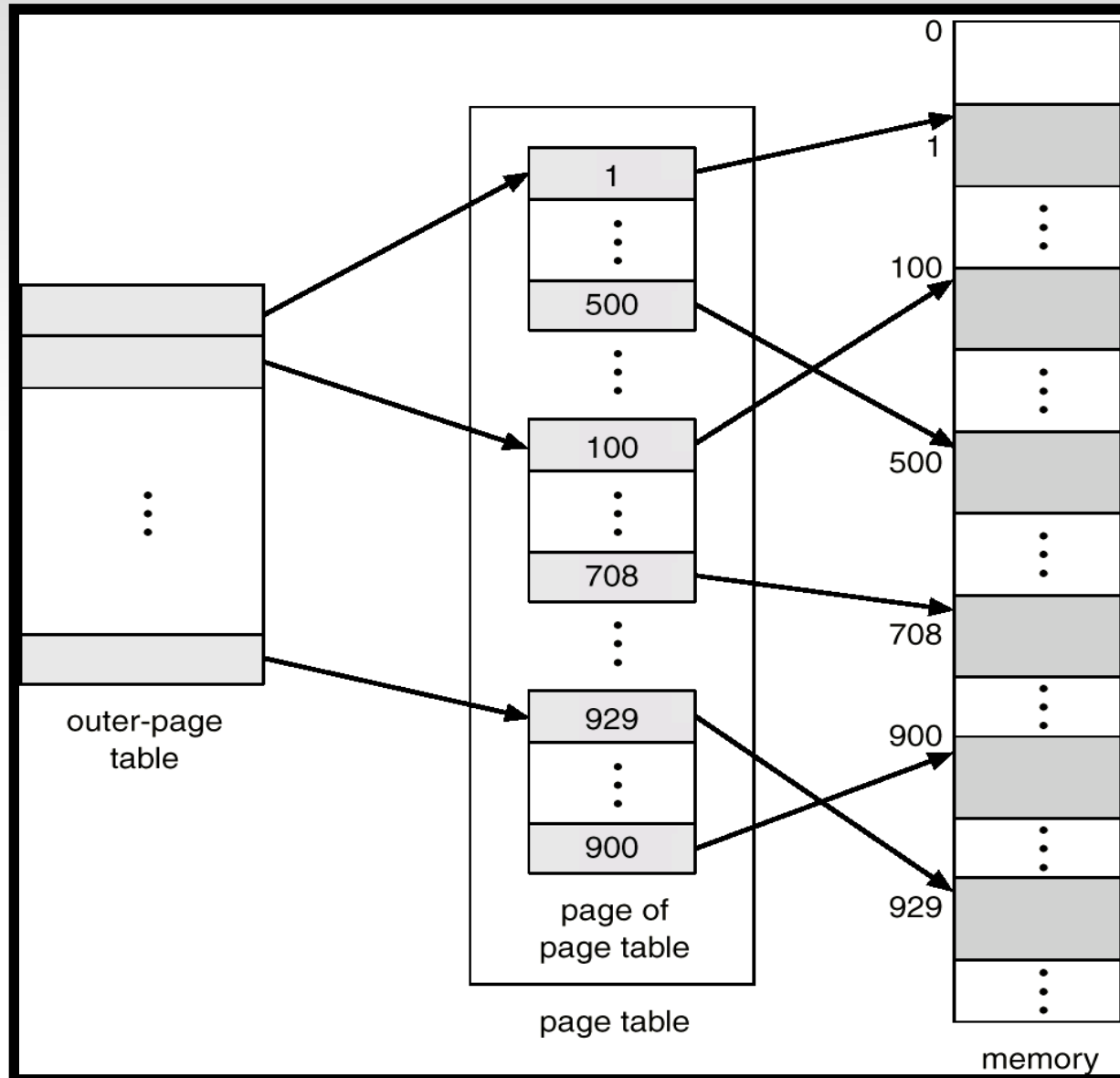

# Example: two level pages

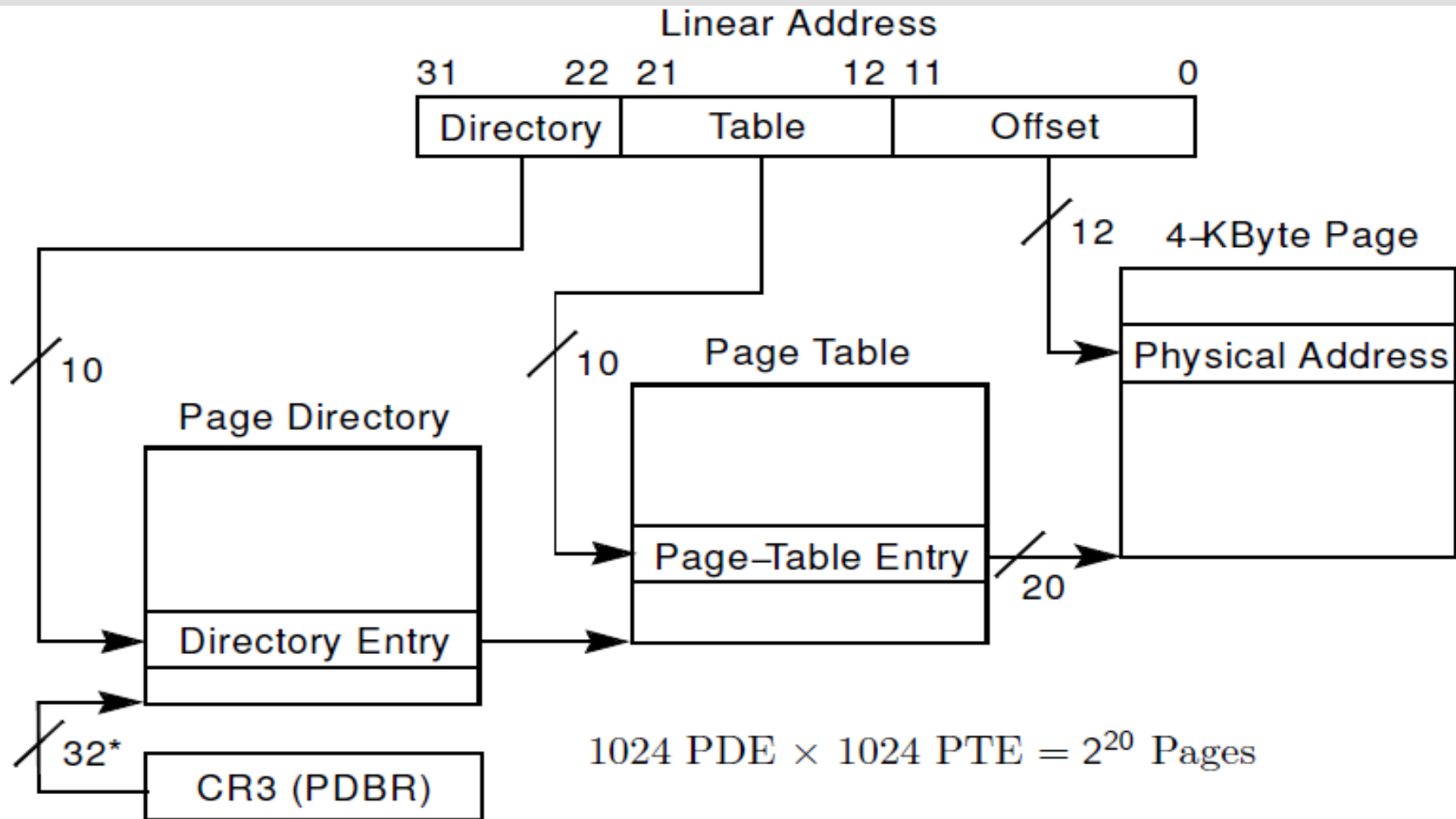

\*32 bits aligned onto a 4-KByte boundary

# On demand paging

- Virtual memory > physical memory
  - Some pages are not present in memory (X)
  - Stored on disk

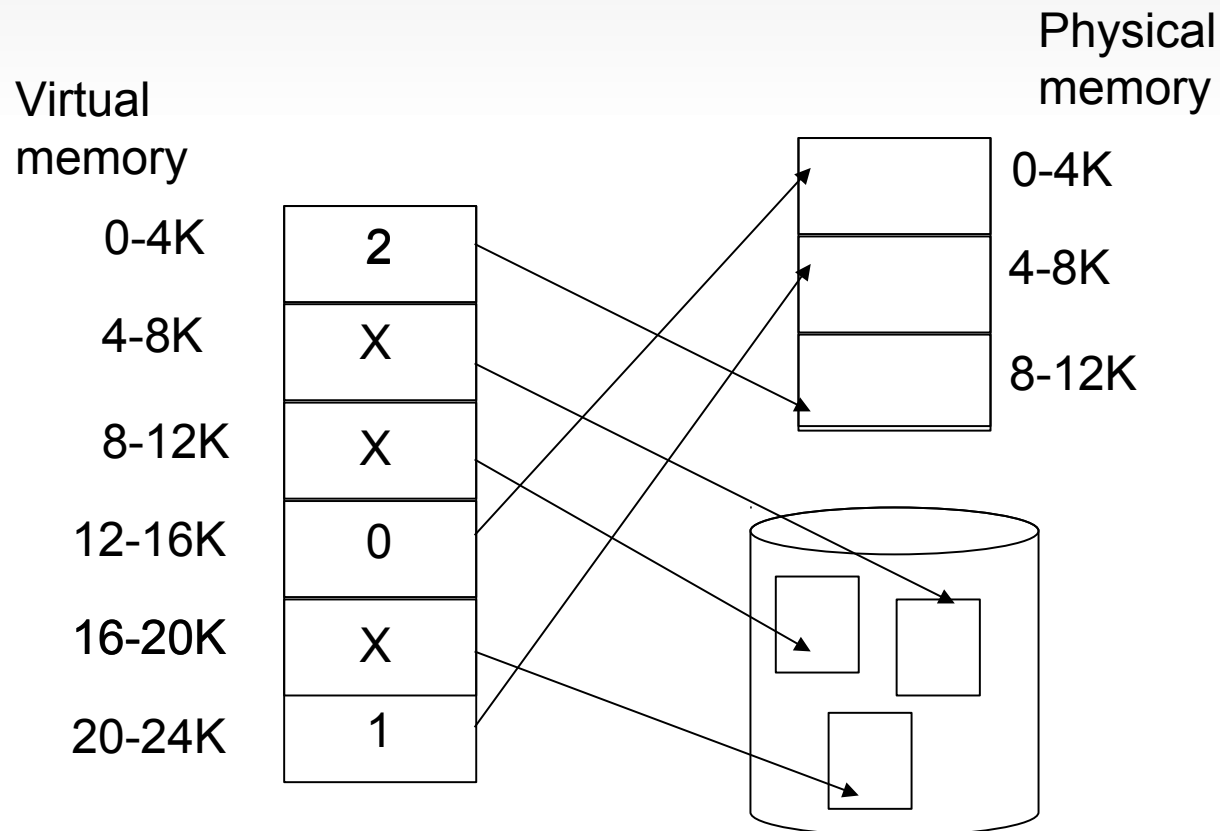

# Page fault

- Access to an absent page
  - Presence bit
  - Page fault (Trap to OS)
- Page fault management
  - Find a free physical frame
    - If there is a free frame; use it
    - Else, select a page to replace (to free a frame)
    - Save the replaced page on disk if necessary (dirty page)
  - Load the page from disk in the physical frame
  - Update page table
  - Restart instruction
- Require a presence bit, a dirty bit, a disk @ in the page table
- Different page replacement algorithms

# On demand paging

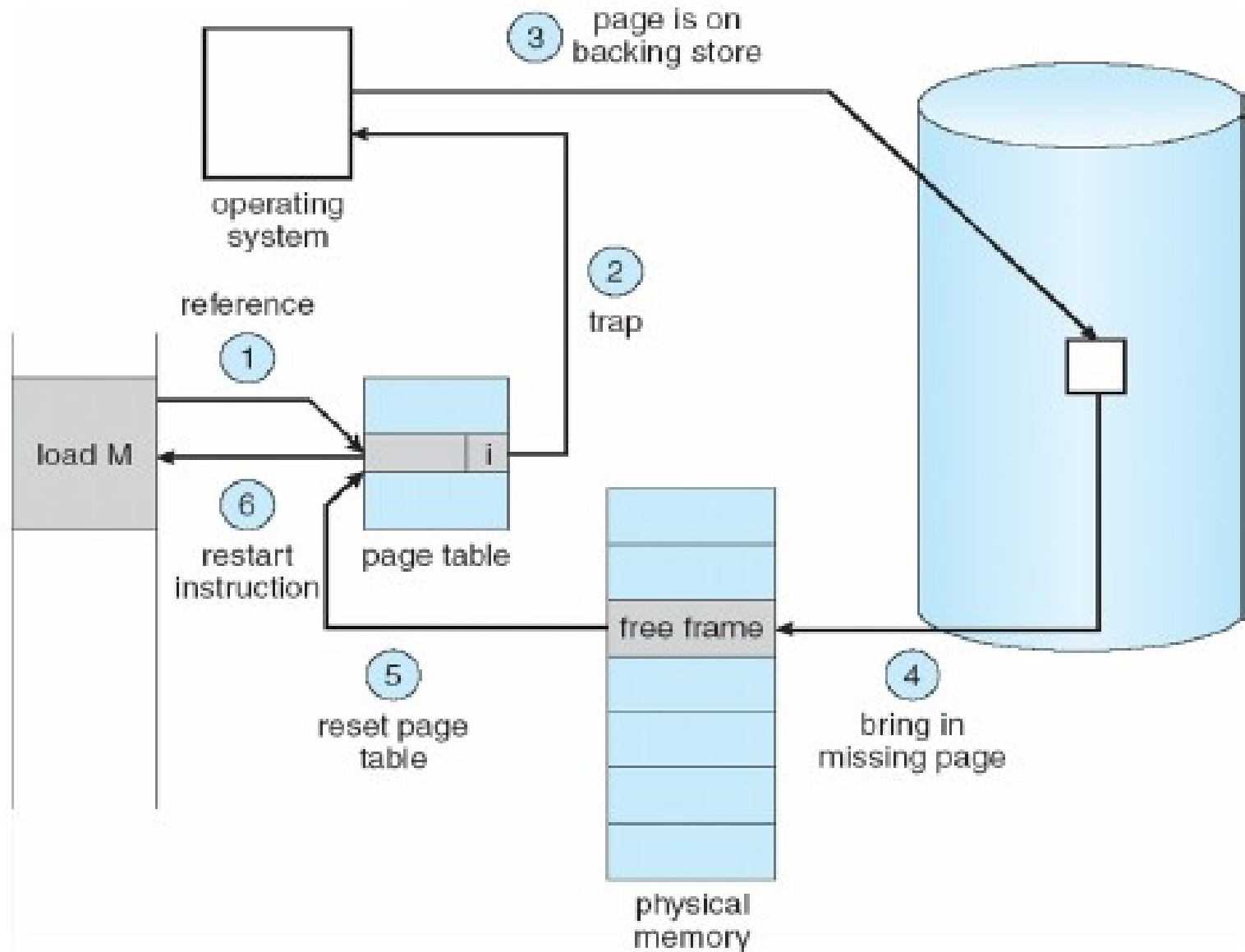

# Page replacement algorithms

- Working set model
- Algorithms
  - Optimal
  - FIFO
  - Second chance
  - LRU



# Working set model

- Disk much much slower than memory (RAM)
  - Goal: run at memory (not disk) speed
- 90/10 rule: 10% of memory gets 90% of memory refs
  - So, keep that 10% in real memory, the other 90% on disk

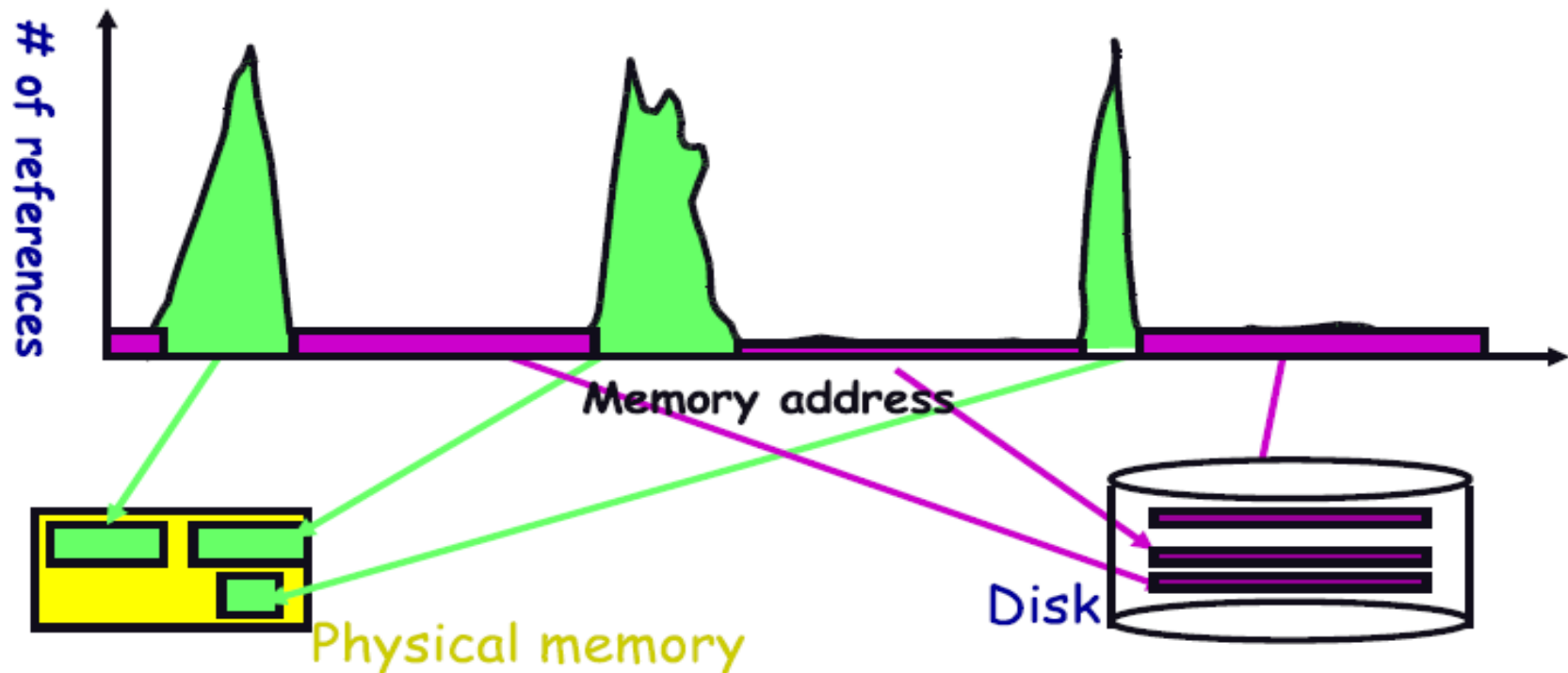

# Optimal page replacement

- What is optimal (if you knew the future)?
  - Replace pages that will not be used for longest period of time
- Example
  - Reference string : 0,1,2,3,0,1,4,0,1,2,3,4,1,2
  - 4 physicals frames:

0	0	3
1	1	1
2	2	2
3	4	4

6 pages faults

# FiFo

- Evict oldest page in system
- Example
  - Reference string : 0,1,2,3,0,1,4,0,1,2,3,4,1,2
  - 4 physical frames:

10 page faults

0	4	4	4	4	3	3
1	1	0	0	0	0	4
2	2	2	1	1	1	1
3	3	3	3	2	2	2

- Implementation: just a list

# LRU page replacement

- Approximate optimal with least recently used
  - Because past often predicts the future
- Example
  - Reference string : 0,1,2,3,0,1,4,0,1,2,3,4,1,2
  - 4 physical frames:

0	0	0	0	4
1	1	1	1	1
2	4	4	3	3
3	3	2	2	2

8 page faults

# LRU implementation

- Expensive
  - Need specific hardware
- Approximate LRU
  - The aging algorithm
    - Add a counter for each page (the date)
    - On a page access, all page counters are shifted right, inject 1 for the accessed page, else 0
    - On a page fault, remove the page with the lowest counter

# Aging : example

Accessed page	Date Page0	Date Page1	Date Page2	Order pages /date
	000	000	000	
Page 0	<b>1</b> 00	000	000	P0,P1=P2
Page 1	0 <b>1</b> 0	<b>1</b> 00	000	P1,P0,P2
Page 2	00 <b>1</b>	0 <b>1</b> 0	<b>1</b> 00	P2,P1,P0
Page 1	000	<b>1</b> 0 <b>1</b>	0 <b>1</b> 0	P1,P2,P0

P0 is the oldest

# Second chance

- Simple FIFO modification
  - Use an access bit R for each page
    - Set to 1 when page is referenced
    - Periodically reset by hardware
  - Inspect the R bit of the oldest page (of the FIFO list)
    - If 0 : replace the page
    - If 1 : clear the bit, put the page at the end of the list, and repeat
- Approximation of LRU

# Page buffering

- Naïve paging
  - Page replacement : 2 disk IO per page fault
- Reduce the IO on the critical path
  - Keep a pool of free frames
    - Fetch the page in an already free page
    - Swap out a page in background



# Paging

- Separate linking from memory concern
- Simplifies allocation, free and swap
- Eliminate external fragmentation
- May leverage internal fragmentation

# Resources you can read

- [http://en.wikipedia.org/wiki/Page\\_table](http://en.wikipedia.org/wiki/Page_table)
  - Wikipedia can always be useful
- Operating System Concepts, 8th Edition, Abraham Silberschatz, Peter B. Galvin, Greg Gagne
  - <http://os-book.com/>
  - Chapters 7 & 8
- Modern Operating Systems, Andrew Tanenbaum
  - <http://www.cs.vu.nl/~ast/books/mos2/>
  - Chapter 4